



OTROS PRODUCTOS PARA SU SERVICIO / OTHER PRODUCTS FOR SERVICE



Sellos Mecánicos de Proceso



Sellos Monoresorte



Sellado de Fugas en Vivo

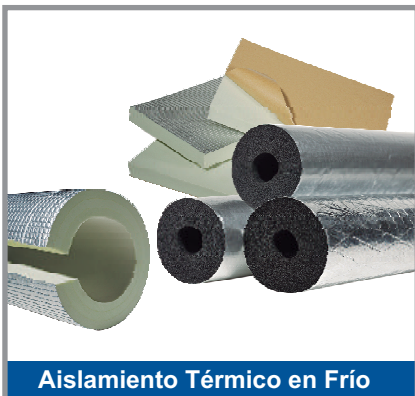

Aislamiento Térmico en Frío



Aislamiento Térmico en Caliente



(Stop Leak) Reparador de Tuberías

•0023/Rev.02/15

sealco@cisealco.com

PBX:(574) 370 47 00

FAX:(574) 281 73 27

Avenida 37 B N° 38 A-12 (Itagüí -Colombia)

www.cisealco.com



DISTRIBUIDO POR :



■ MT 4200 GRAFITO REFORZADO CON CARBÓN CARBON REINFORCED GRAPHITE

• Hilos de carbón de alta resistencia refuerzan las esquinas para soportar mayores presiones sin necesidad de anillos de soporte. Soporta 3000 °C en atmósferas reductoras, 1000°C en vapor y 480 °C en atmósferas oxidantes. Es la mejor empaquetadura que existe actualmente en el mundo.

• Style MT 4200 is a pure graphite packing with very high resistance to pressure and mechanical loading. Resistant to all chemical products, except strong oxidizers.

t °C	▲	▣	⊕
		-200+3000	
p bar	350	200	180
v m/s	2,5	1,5	25
pH		1-14	

■ MT 4400 GRAFITO REFORZADO CON KEVLAR KEVLAR REINFORCED GRAPHITE

• Hilos de grafito reforzados con carbón son multi trenzados para conformar una empaquetadura reforzada con hilo aramídico en las esquinas. Empaquetadura que ha sido diseñada especialmente para ser utilizada al servicio con bombas reciprocantes, altas presiones y en el y manejo de abrasivos

• Carbon Reinforced graphite fibers are multi braided to conformate a resistant packing with aramidic fibers in the edges. This packing has been specially designed to reciprocating pumps service, high pressures and severe abrasives handling.



t °C	▲	▣	⊕
		-100+260	
p bar	350	250	200
v m/s	1,5	3	20
pH		1-12	

RELACIÓN METROS x KG EMPAQUETADURAS DE COMPRESIÓN / RELATIONSHIP METERS x KG PACKING COMPRESSION

TOLERANCIAS/TOLERANCES		1/8" - 1 1/2"										± 10 %					
1/8"	3/16"	1/4"	5/16"	3/8"	7/16"	1/2"	9/12"	5/8"	3/4"	7/8"	1"	1 1/8"	1 1/4"	1 1/2"			
—	37,60	21,28	13,50	9,90	7,50	6,20	5,00	3,70	3,00	2,31	1,80	—	—	—	1,18	—	—

RELACIÓN METROS x KG EMPAQUETADURAS DE COMPRESIÓN / RELATIONSHIP METERS x KG PACKING COMPRESSION

TOLERANCIAS/TOLERANCES		1/8" - 1 1/2"										± 10 %					
1/8"	3/16"	1/4"	5/16"	3/8"	7/16"	1/2"	9/12"	5/8"	3/4"	7/8"	1"	1 1/8"	1 1/4"	1 1/2"			
—	—	—	12,00	9,60	6,50	5,03	—	3,90	2,70	—	—	—	—	—	—	—	—



■ MT 9010 FIBRA GFO GFO FIBER

• Se fabrica con hilos de GFO, ideal para estandarizar las plantas. Se utiliza con solventes, aceites, gases, ácidos fuertes, álcalis fuertes y derivados del petróleo, etc. No usa con oxidantes fuertes. No raya ejes. Tenemos también una versión económica MT 9010A.

• This packing consists of interbraided yarns of GFO Fiber, with pure graphite structurally incorporated. The chemical inertia of PTFE, the high thermal conductivity of graphite, the type of lubricant used in its manufacture and its low friction coefficient make it ideally applicable within a wide field of chemical substances such as solvents, oils, gases, strong acids and alkalies and petroleum derivatives. Also have an economical version MT 9010A

t °C	▲	▣	⊕
		-200+280	
p bar	300	200	35
v m/s	2	1,5	25
pH		0-14	

■ MT 8400 FENÓLICA DE ALTO DESEMPEÑO HIGH PERFORMANCE PHENOLIC

• Fibra fenólica especial para sellar ejes desalineados y soportar altas presiones. Se utiliza en papeleras, textiles, productos químicos y la industria en general. Tiene recubrimientos de PTFE, no requiere ajustes frecuentes.

• Diagonally woven braid obtained with phenolic yarns, singly treated with pure PTFE dispersion and with inert lubricant. For applications in pumps, valves, pistons with acid products, condensate water, solvents, pulp and paper products, sugar mill products, abrasive fluids, etc.



t °C	▲	▣	⊕
		-100+260	
p bar	400	100	50
v m/s	1,5	1	15
pH		0-13	

RELACIÓN METROS x KG / RELATIONSHIP METERS x KG

TOLERANCIAS/TOLERANCES		1/8" - 1 1/2"										± 10 %					
1/8"	3/16"	1/4"	5/16"	3/8"	7/16"	1/2"	9/12"	5/8"	3/4"	7/8"	1"	1 1/8"	1 1/4"	1 1/2"			
—	58,15	24,8	13,5	9,80	7,20	5,50	4,10	3,30	2,70	1,90	1,40	1,15	—	—	0,80	—	—

RELACIÓN METROS x KG / RELATIONSHIP METERS x KG

TOLERANCIAS/TOLERANCES		1/8" - 1 1/2"										± 10 %					
1/8"	3/16"	1/4"	5/16"	3/8"	7/16"	1/2"	9/12"	5/8"	3/4"	7/8"	1"	1 1/8"	1 1/4"	1 1/2"			
—	29,40	15,00	10,50	7,70	5,70	4,60	—	3,00	2,00	1,60	1,10	—	—	—	—	—	—

■ MT 8011 EMPAQUETADURA TIGRE TIGER PACKING



• Fabricada con fibras aramidas en las esquinas y PTFE grafito. Especial para el manejo de todo tipo de abrasivos: De gran aplicación en centrales azucareras, mineras, pulpa, agua salada, etc. No raya ejes. También tenemos una versión económica MT 8011A.

• Manufactured in a particular process, the PTFE yard braided with aramid yarn in the corners. For pumps, agitators, valves, mixers, acids, solvents, abrasive substances, food industries and papermills. Also have an economical version MT 8011A.

t °C	▲	▣	⊕
		-100+280	
p bar	350	250	50
v m/s	1,5	3	20
pH		2-12	

■ MT 8010 FIBRA ARAMIDA 100% 100% ARAMIDIC FIBER



• Se fabrica con hilos fabricados de aramida 100% y se recomienda para aplicaciones con presencia de abrasivos o slurries en las industrias azucareras, mineras, cementeras, cerámica, pulpa y otras. Tenemos también una versión económica MT 8010A.

• Made from continuous aramid fibres which are with which PTFE dispersion and lubricants, it is not flammable and thermostable. Suitable for centrifugal and piston pumps, slide and low pressure valves. Also have an economical version MT 8010A.

t °C	▲	▣	⊕
		-100+280	
p bar	220	100	50
v m/s	2	1,5	15
pH		2-12	

RELACIÓN METROS x KG / RELATIONSHIP METERS x KG

TOLERANCIAS/TOLERANCES		1/8" - 1 1/2"										± 10 %					
1/8"	3/16"	1/4"	5/16"	3/8"	7/16"	1/2"	9/12"	5/8"	3/4"	7/8"	1"	1 1/8"	1 1/4"	1 1/2"			
—	58,15	24,8	13,5	9,80	7,20	5,50	4,10	3,30	2,70	1,90	1,40	1,15	—	—	0,80	—	—

RELACIÓN METROS x KG / RELATIONSHIP METERS x KG

TOLERANCIAS/TOLERANCES		1/8" - 1 1/2"										± 10 %					
1/8"	3/16"	1/4"	5/16"	3/8"	7/16"	1/2"	9/12"	5/8"	3/4"	7/8"	1"	1 1/8"	1 1/4"	1 1/2"			
—	54,10	25,90	15,94	10,70	7,20	6,10	4,10	3,50	3,10	2,20	1,45	1,20	—	—	—	—	—

■ MT 8015 CORDON ZEBRA ZEBRA PACKING



t °C	▲	▣	⊗
	-100	+250	
p bar	350	250	70
v m/s	1,5	3	2,5
pH	3-12		

• Hilos de fibra aramida trenzada conjuntamente con hilos de PTFE-grafito. Le permite soportar altas presiones, sellar productos muy abrasivos, absorber desalineamientos de eje. Posee alta resistencia mecánica y una excelente lubricación.

• Aramid fiber yarns braided together with yarns Teflon-graphite. Enables it to withstand high pressure and abrasives, absorb high shaft misalignments. Has high strength and excellent lubrication properties.

RELACIÓN METROS x KG / RELATIONSHIP METERS x KG														
TOLERANCIAS/TOLERANCES		1/8" - 1 1/2"										± 10 %		
1/8"	3/16"	1/4"	5/16"	3/8"	7/16"	1/2"	9/12"	5/8"	3/4"	7/8"	1"	1 1/8"	1 1/4"	1 1/2"
—	—	—	9,60	7,59	—	4,00	—	—	—	—	—	—	—	—

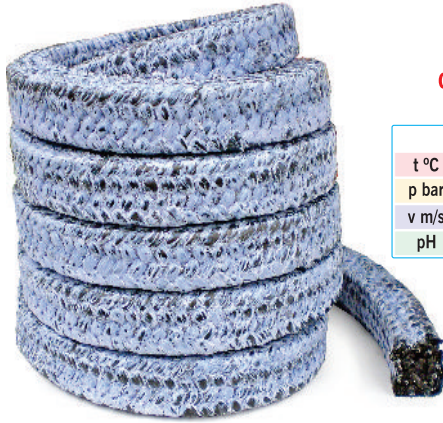

■ MT 3110 CARBÓN TEFLONADA PTFE CARBON

t °C	▲	▣	⊗
	-60	+345	
p bar	200	100	50
v m/s	1,5	1,5	25
pH	0-14		

• Los filamentos de carbón, se tratan con una suspensión de PTFE. Se utiliza con ácidos y cáusticos fuertes, vapor, aceites y solventes. Se utiliza en equipo de

fábricas de pulpa, refinerías, bombas, agitadores y válvulas. No se recomienda con oxidantes fuertes.

• Made from carbon yarns impregnated with PTFE. For alternative and centrifugal pumps and low pressure valves. Excellent with acids, fumes, gas, oils, and solvents, except strong oxidizers.

RELACIÓN METROS x KG / RELATIONSHIP METERS x KG														
TOLERANCIAS/TOLERANCES		1/8" - 1 1/2"										± 10 %		
1/8"	3/16"	1/4"	5/16"	3/8"	7/16"	1/2"	9/12"	5/8"	3/4"	7/8"	1"	1 1/8"	1 1/4"	1 1/2"
57,0	39,0	22,0	14,00	8,0	5,0	4,3	3,4	2,8	1,9	1,4	1,0	—	—	—

■ MT 1110 Nap SINTÉTICO TEFLONADO PTFE SYNTHETIC FIBER



• Económico reemplazo de las fibras de asbesto. Se fabrica en fibra acrílica impregnada en PTFE y lubricantes parafínicos. Para uso en productos que requieran resistencia química y no contaminación por color como: papeleros, alimentos, centrales azucareras, industria textil, etc.

t °C	▲	▣	⊗
	-100	+250	
p bar	100	80	20
v m/s	1,5	2	15
pH	2-12		

• A new synthetic fibre with PTFE impregnation and silicon free lubricants is our alternative to asbestos and toxic packings. For uses in papermills, food and sugar industries.

RELACIÓN METROS x KG / RELATIONSHIP METERS x KG														
TOLERANCIAS/TOLERANCES		1/8" - 1 1/2"										± 10 %		
1/8"	3/16"	1/4"	5/16"	3/8"	7/16"	1/2"	9/12"	5/8"	3/4"	7/8"	1"	1 1/8"	1 1/4"	1 1/2"
48,20	24,10	15,30	10,60	7,50	5,56	4,32	3,30	2,90	1,89	1,45	1,11	0,94	0,69	—

■ MT 8012 FIBRA ARAMIDA ANTIDESGASTE ANTI WEARING ARAMID PACKING

NEW



• Hilos de Aramida impregnadas con grafito y PTFE son trenzadas para formar una empaquetadura altamente resistente a los abrasivos sin rayas ejes. Posee alta resistencia mecánica y la resistencia química de las Aramidás.

• Yarns of aramide are impregnated with PTFE and Graphite to obtain a special packing to seal abrasives and slurries without the wearing effect of aramid's fibres.

t °C	▲	▣	⊗
	-200	+280	
p bar	300	250	30
v m/s	—	2	25
pH	2-12		

RELACIÓN METROS x KG / RELATIONSHIP METERS x KG														
TOLERANCIAS/TOLERANCES		1/8" - 1 1/2"										± 10 %		
1/8"	3/16"	1/4"	5/16"	3/8"	7/16"	1/2"	9/12"	5/8"	3/4"	7/8"	1"	1 1/8"	1 1/4"	1 1/2"
—	—	—	19,50	13,10	8,70	6,50	5,20	4,50	3,10	2,00	—	1,90	—	—

■ MT 3010 CARBÓN PURO PURE CARBON

• Empaquetadura fabricada con hilos de carbón y lubricantes. Se usa en aplicaciones de agua caliente, vapor, condensados, criogénicos, etc. No usar en oxidantes fuertes como aleum, ácido nítrico, etc. En vapor soporta 345°C.

t °C	▲	▣	⊗
	-50	+650	
p bar	200	100	35
v m/s	2,5	1-5	25
pH	0-14		

• Packing in pure carbon yarns impregnated with lubricants: oil, graphite and MoS2. Used in boiler feedwater pumps, steam in low pressure valves. Not recommended for strong oxidizers.



RELACIÓN METROS x KG / RELATIONSHIP METERS x KG														
TOLERANCIAS/TOLERANCES		1/8" - 1 1/2"										± 10 %		
1/8"	3/16"	1/4"	5/16"	3/8"	7/16"	1/2"	9/12"	5/8"	3/4"	7/8"	1"	1 1/8"	1 1/4"	1 1/2"
—	—	—	—	—	8,54	5,50	—	3,40	—	—	—	—	—	—

■ MT 2011 EMPAQUETADURA DIAMANTE DIAMOND PACKING

• Especial para productos alimenticios y farmacéuticos que sean abrasivos y/o tengan tendencia a cristalizarse. Se utiliza con solventes, ácidos medios, gases, productos alcalinos, productos agresivos a excepción del oxígeno y de los que atacan la aramida y el PTFE.

• Made from pure PTFE fibres, corners are reinforced with aramid yarns. Ideal for food and chemical industries. For pumps, piston pumps, valves, agitators, acids, solvents, abrasive substances.

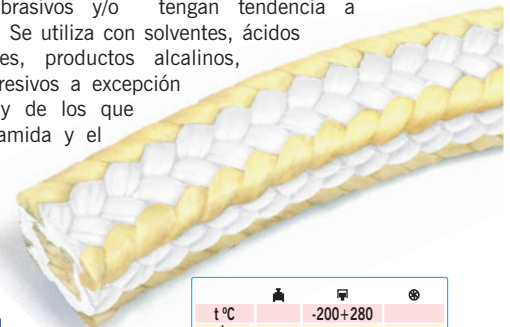

t °C	▲	▣	⊗
	-200	+280	
p bar	200	150	30
v m/s	1,5	1	15
pH	2-12		

RELACIÓN METROS x KG EMPAQUETADURAS DE COMPRESIÓN / RELATIONSHIP METERS x KG PACKING COMPRESSION														
TOLERANCIAS/TOLERANCES		1/8" - 1 1/2"										± 10 %		
1/8"	3/16"	1/4"	5/16"	3/8"	7/16"	1/2"	9/12"	5/8"	3/4"	7/8"	1"	1 1/8"	1 1/4"	1 1/2"
—	—	—	14,10	10,04	6,70	5,40	3,90	3,26	2,59	1,75	—	1,12	—	0,68

■ MT 1210 ASBESTO GRAFITADO GRAPHITIZED ASBESTOS

• Empaquetadura de uso general. Cada hebra es revestida de grafito así como la superficie total de la trenza para obtener el máximo de lubricación y evitar el rayado de ejes. Se recomienda para sellar ácidos y alcalinos débiles, agua, vapor, salmuera, aceites, etc. Nuestra 1210 NAP, reemplaza esta referencia cuando no se requiere usar asbesto.

t °C	⚙️	⚙️	⚙️
		-50+316	⊕
p bar	60	40	20
v m/s	1,5	3	10
pH		4-10	

• This reference is a low cost packing for general use. Recommended for sealing weak acids and alkalis, water, steam, brines and oils.



RELACIÓN METROS x KG / RELATIONSHIP METERS x KG														
TOLERANCIAS/TOLERANCES		1/8" - 1 1/2"										± 10 %		
1/8"	3/16"	1/4"	5/16"	3/8"	7/16"	1/2"	9/12"	5/8"	3/4"	7/8"	1"	1 1/8"	1 1/4"	1 1/2"
65,80	31,40	17,80	12,90	8,80	6,30	4,41	3,70	3,03	2,09	1,59	1,22	1,04	0,81	0,60

FIBRA VEGETAL ENCEBADA VEGETABLE FIBER WITH LUBRICANT ■ MT 7310

• Hilos de fibra vegetal se trenzan e impregnan en cebo y lubricantes antidesgaste. De gran aplicación en servicio marino, hidroeléctricas y aplicaciones no agresivas. Se usa en agua salada, agua fría, aceites, etc. No raya ejes.

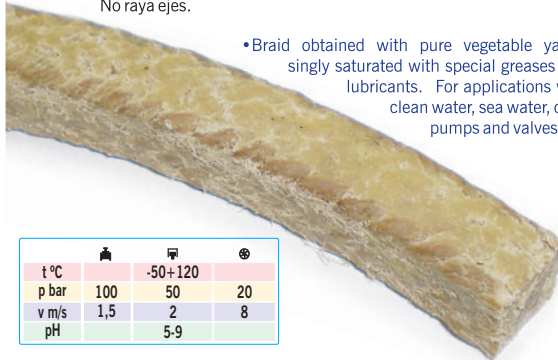

• Braid obtained with pure vegetable yarns, singly saturated with special greases and lubricants. For applications with clean water, sea water, oil in pumps and valves.

t °C	⚙️	⚙️	⊕
		-50+120	⊕
p bar	100	50	20
v m/s	1,5	2	8
pH		5-9	

RELACIÓN METROS x KG / RELATIONSHIP METERS x KG														
TOLERANCIAS/TOLERANCES		1/8" - 1 1/2"										± 10 %		
1/8"	3/16"	1/4"	5/16"	3/8"	7/16"	1/2"	9/12"	5/8"	3/4"	7/8"	1"	1 1/8"	1 1/4"	1 1/2"
66,00	23,60	19,36	12,50	9,90	7,40	5,70	4,87	3,70	2,40	1,76	1,50	1,20	1,05	0,80

EMPAQUETADURAS PARA BOMBAS PUMP PACKINGS

■ MT 1110 ASBESTO TEFLONADO TEFLONIZED ASBESTOS

• El teflón que recubre cada hilo de asbesto y a todo el conjunto de la trenza, le imparte una excelente resistencia química y un bajo coeficiente de fricción. Se utiliza con ácidos y cáusticos de mediana agresividad, aire, agua, gases, solventes, aceites y en general productos químicos.

t °C	⚙️	⚙️	⊕
		-100+260	⊕
p bar	100	80	20
v m/s	1,5	2	15
pH		3-12	

• Individual yarns of asbestos are first individually treated with teflon and then interbraided and treated again so as to give this packing excellent chemical resistance and a low friction factor. Applicable in the cases of moderately aggressive acids and alkalis, air, water, gases, solvents, oils and chemical substances in general.



RELACIÓN METROS x KG / RELATIONSHIP METERS x KG														
TOLERANCIAS/TOLERANCES		1/8" - 1 1/2"										± 10 %		
1/8"	3/16"	1/4"	5/16"	3/8"	7/16"	1/2"	9/12"	5/8"	3/4"	7/8"	1"	1 1/8"	1 1/4"	1 1/2"
55,80	24,00	15,20	10,50	6,80	5,12	3,80	3,16	2,42	1,70	1,25	0,99	0,90	0,70	0,55

FIBRA VEGETAL TEFLONADA TEFLONIZED VEGETABLE FIBER ■ MT 7110

• Fabricado con hilos de fibra vegetal impregnados con PTFE y aceites especiales. Es muy resistente a aceites, grasa, combustible, solventes y agua salada. De gran aplicación en industria papelera. No raya ejes.

• Made from pure vegetable yarns with PTFE impregnation, it does not damage or groove shafts and sleeves. It is very resistant to fuel, oils, greases, salt water and solvents. Suitable for centrifugal and piston pumps, in breweries, refineries and sugarmills

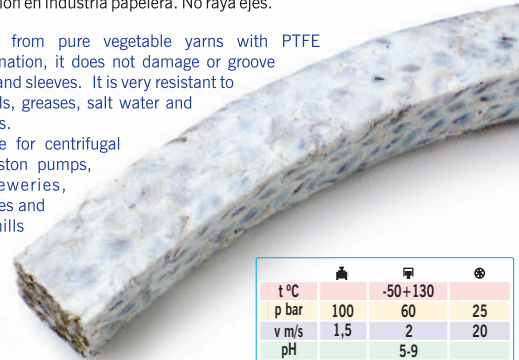

t °C	⚙️	⚙️	⊕
		-50+130	⊕
p bar	100	60	25
v m/s	1,5	2	20
pH		5-9	

RELACIÓN METROS x KG / RELATIONSHIP METERS x KG														
TOLERANCIAS/TOLERANCES		1/8" - 1 1/2"										± 10 %		
1/8"	3/16"	1/4"	5/16"	3/8"	7/16"	1/2"	9/12"	5/8"	3/4"	7/8"	1"	1 1/8"	1 1/4"	1 1/2"
—	25,60	15,50	11,20	8,10	6,90	4,80	3,66	3,20	2,26	1,50	1,27	1,10	—	—

EMPAQUETADURAS PARA VÁLVULAS / VALVE PACKINGS

GRAFITO EXPANDIDO CON INCONEL EXPANDED GRAPHITE WITH INCONEL ■ MT 4300



• Hilos de grafito flexible expandido sin aglutinantes con inserción de inconel son multitrenzados para conformar una empaquetadura de excelente lubricidad, alta resistencia térmica y mecánica, su refuerzo de inconel le permite soportar mayores presiones sin necesidad de anillos de soporte. De gran aplicación en válvulas de vapor, petroleras, juntas de expansión, plantas químicas; resiste todos los productos químicos excepto agentes oxidantes fuertes.

t °C	⚙️	⚙️	⊕
		-200+650	⊕
p bar	250	120	100
v m/s	2,5	1,5	25
pH		1-14	

• Flexible expanded graphite fibers without binders and with inconel insertion are multibraided to conform a packing with excellent lubricity, high mechanical and thermal resistance.

RELACIÓN METROS x KG / RELATIONSHIP METERS x KG														
TOLERANCIAS/TOLERANCES		1/8" - 1 1/2"										± 10 %		
1/8"	3/16"	1/4"	5/16"	3/8"	7/16"	1/2"	9/12"	5/8"	3/4"	7/8"	1"	1 1/8"	1 1/4"	1 1/2"
50,00	43,00	22,50	17,30	9,30	7,90	6,90	5,70	5,10	3,10	2,80	2,13	—	—	—

■ MT 2013 PTFE PURO TRATADO PARA VÁLVULAS TREATED PTFE FOR VALVES

• Hilos de PTFE puro son tratados con una dispersión de PTFE y son trenzados. Es ideal para productos alimenticios, farmacéuticos y corrosivos. Su principal aplicación se encuentra en todo tipo de válvulas, ejes alternativos de baja velocidad y en sellado estático. También tenemos una versión económica MT 2013A.



• This packing is made using pure, virgin PTFE monofilament fibres. It has gone through a double impregnation, firstly on each strand, secondly in dispersion. Suitable in all acid and basic fluids compatible with PTFE. Also have an economical version MT 2013A.

t °C	⚙️	⚙️	⊕
		-200+280	⊕
p bar	250	n/a	n/a
v m/s	2,5	n/a	n/a
pH		0-14	

RELACIÓN METROS x KG / RELATIONSHIP METERS x KG														
TOLERANCIAS/TOLERANCES		1/8" - 1 1/2"										± 10 %		
1/8"	3/16"	1/4"	5/16"	3/8"	7/16"	1/2"	9/12"	5/8"	3/4"	7/8"	1"	1 1/8"	1 1/4"	1 1/2"
—	—	15,50	13,40	7,78	5,70	5,10	4,90	3,30	2,00	1,65	1,30	—	—	0,60

CERÁMICA CON INCONEL
CERAMIC WITH INCONEL ■ **1450W**



• Hilos de fibra cerámica (no asbesto) reforzados con inserción metálica, son multitrenzados en una mezcla elastomérica para conformar una empaquetadura de gran estabilidad dimensional y resistencia térmica y mecánica. Se usa para sellar vapor saturado, sobresaturado, aire y gases calientes, productos derivados del petróleo, productos químicos y otros.

• Ceramic fibers (non asbestos) are reinforced with metallic insertions, those fibers are multibraided to conform an elastomeric mix with high dimensional stability and thermic and mechanical resistance. Is used to seal saturated vapor, over saturated, air and hot gas, oil products, chemical products and others.

t °C	♠	♣	⊕
		-500+700	
p bar	400	n/a	n/a
v m/s	2	n/a	n/a
pH		2-14	

RELACION METROS x KG / RELATIONSHIP METERS x KG

TOLERANCIAS/TOLERANCES		1/8" - 1 1/2"										± 10 %					
1/8"	3/16"	1/4"	5/16"	3/8"	7/16"	1/2"	9/12"	5/8"	3/4"	7/8"	1"	1 1/8"	1 1/4"	1 1/2"			
50,00	34,00	19,10	12,62	9,50	5,90	5,30	4,20	3,45	2,40	1,88	1,82						

EMPAQUETADURAS PARA BOMBAS
PUMP PACKINGS

■ **MT 2010** PTFE PURO
PURE PTFE

• Empaquetadura de PTFE puro, es impregnada en aceites especiales. Posee una excelente resistencia a los productos químicos tales como ácidos fuertes, álcalis y solventes. No se recomienda su utilización con flúor y metales alcalinos drettidos. Tenemos también una versión económica MT 2010A.



• Yarns of pure PTFE are interbraided and impregnated with specials oils to give this packing excellent resistance to highly aggressive chemical substances, such as acids, alkalies and solvents. This reference is a soft, flexible packing with a low friction which does not vitrify at high velocities. Also have an economical version MT 2010A.

t °C	♠	♣	⊕
		-200+280	
p bar	100	100	30
v m/s	1	2	12
pH		0-14	

RELACION METROS x KG / RELATIONSHIP METERS x KG

TOLERANCIAS/TOLERANCES		1/8" - 1 1/2"										± 10 %					
1/8"	3/16"	1/4"	5/16"	3/8"	7/16"	1/2"	9/12"	5/8"	3/4"	7/8"	1"	1 1/8"	1 1/4"	1 1/2"			
57,00	25,50	13,49	9,20	6,59	4,20	3,60	3,24	2,45	1,76	1,30	1,01		0,66	0,45			

■ **SealPack** MASILLA INYECTABLE 5453
INJECTABLE PUTTY 5453



• Masilla sellante, fabricada a partir de fibras sintéticas y lubricantes sólidas, con puntos de fusión controlados. No contiene asbesto. Sella ejes rayados y no necesita removerse. Una dimensión sirve en todas las aplicaciones. **También disponible en grado alimenticio. (Ref. 5452).**

• A non asbestos pump and valve sealant manufactured with solid lubricants and greases are strengthened with synthetic fibers. Special designed for damage shafts, reduce friction and seals with virtually zero leakage. One universal size and never needs to be removed. **Available in food grade (Ref. 5452).**

t °C	♠	♣	⊕
		-50+260	
p bar	45	30	20
v m/s	1,5	2	15
pH		0-14	

APLICACIÓN

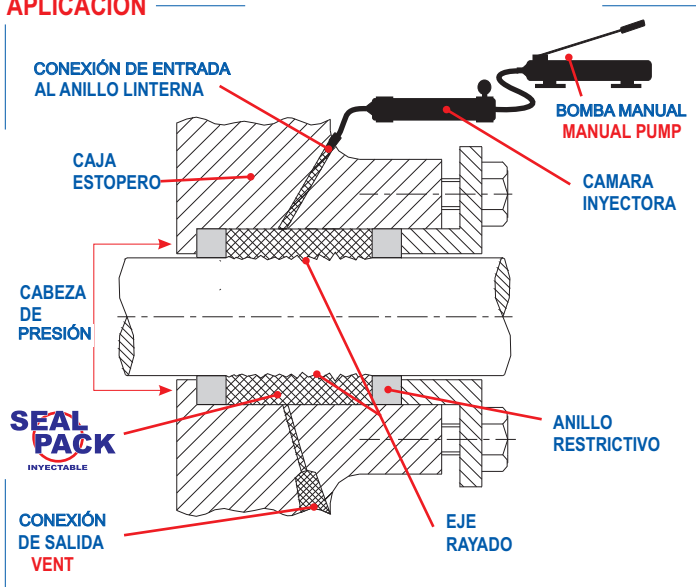

■ **TABLA DE CONVERSIÓN DE VELOCIDADES DE EJES**
SHAFT VELOCITIES CONVERSIONS TABLE

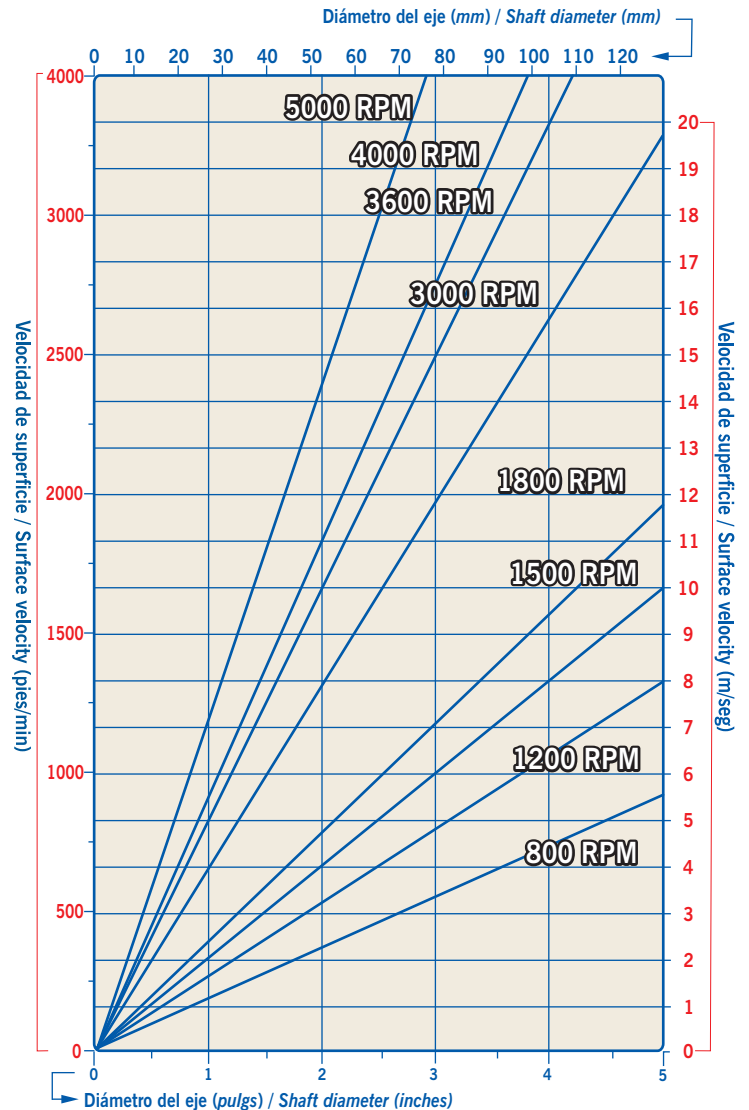

■ Extractores

PACKING HOOKS



- La mejor herramienta para extraer sus anillos de empaquetadura
- Se evitan rayaduras al eje y al estopero.
- Economiza tiempo
- Disminuye pérdidas por paros en producción
- Facilita la labor del mecánico
- Tiene cabezas recambiables.

Order form-Specifications-Flexible

SIZES	LENGTH	CORD SIZE	REMOVABLE HEAD
F0	6"	3/16"	NO
F1	7-1/2"	5/16"	YES
F2	11"	3/8"	YES
F3	14-1/2"	1/2"	YES
F4	19"	5/8"	NO
F5	23"	3/4"	NO
F6	30"	1"	NO

- Our packing hooks are the ideal tools to remove the packing rings
- They save time and avoid losses through production stoppages.
- They facilitate the work of the mechanic
- Tips are removable

■ Cortador de Cordones

CUTTER OF CORDS

¡Su diseño le permite cortar anillos sin tener que enrollar sobre el eje!
It's design allows to cut rings without having to coil on the shaft!

Ventajas:

- Evita enrollar sobre el eje
- Evita desperdicios de empaquetaduras
- Obtiene cortes perfectos a 45° y 90°
- Facilita la elaboración de anillos
- Mejora el sellado al unirse longitud de tramos exactos y cortes perfectos

Advantages:

- It avoids to coil on the shaft
- Avoids waste of packing
- Obtains perfect cuts to 45° and 90°
- Facilitates the production of rings
- You will have exact sections and perfect cuts

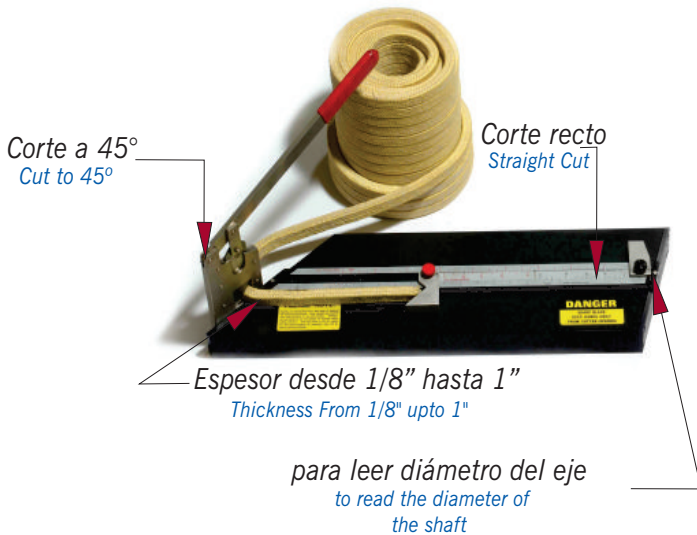

REF.	MAXIMUN DIAMETER OF CUT
SE-4	4" Diameter of the shaft
SE-10	10" Diameter of the shaft

F1	Extractor Flexible	(2)	Flexible Packing Hook(2)
F2	Extractor Flexible	(2)	Flexible Packing Hook(2)
C1	Cabezas Removibles(1)	Removable Tip	(1)
C2	Cabezas Removibles(1)	Removable Tip	(1)
T1	Tirabuzòn	(1)	Corkscrew (1)
T2	Tirabuzòn	(1)	Corkscrew (1)
T3	Tirabuzòn	(1)	Corkscrew (1)
Y	Llave	(1)	Llave (1)

KIT A

Caja plástica incluida
PLASTIC INCLUDED BOX

F1	Extractor Flexible	(2)	Flexible Packing Hook(2)
F2	Extractor Flexible	(2)	Flexible Packing Hook(2)
F3	Extractor Flexible	(2)	Flexible Packing Hook(2)
C1	Cabeza Removible	(1)	Removable Tip (1)
C2	Cabeza Removible	(1)	Removable Tip (1)
C3	Cabeza Removible	(1)	Removable Tip (1)
W1	Cabeza	(1)	Wood Screws Tip (1)
W2	Cabeza	(1)	Wood Screws Tip (1)
W3	Cabeza	(1)	Wood Screws Tip (1)
T1	Tirabuzòn	(1)	Corkscrew (1)
T2	Tirabuzòn	(1)	Corkscrew (1)
T3	Tirabuzòn	(1)	Corkscrew (1)
Y	Llave	(1)	Llave (1)

KIT B

Caja plástica incluida
PLASTIC INCLUDED BOX